

## 45 Class

2-cycle engine

## 70 Class

4-cycle engine

Or Electric equivalent

# MACCHI M.C.205

## INSTRUCTION MANUAL / Montageanleitung

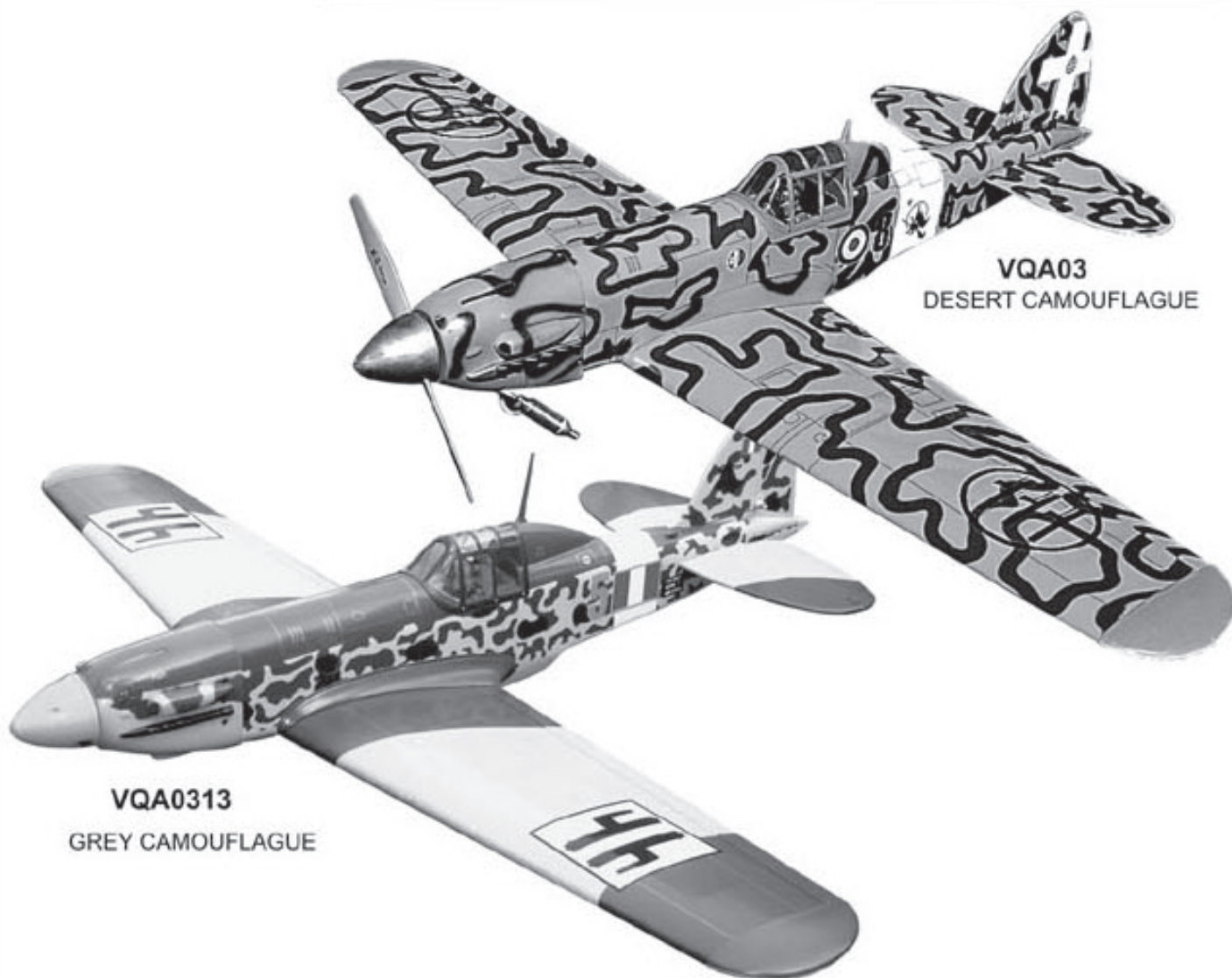

### TECHNISCHE DATEN

Spannweite	1580mm
Länge	1260mm
Elektroantrieb	650 Watt
Verbrennerantrieb	7.5cc 2-T / 11cc 4-T
Fernsteuerung	5 Kanal / 4-5 Servos

### SPECIFICATIONS

Wingspan	1580mm
Length (with spinner)	1260mm
Electric Motor	870 Watt
Glow Engine	.46 2-T / .70 4-T
Radio	4 Channel / 4-5 Servos



**WARNING!** This radio controlled model is NOT a toy. If modified or flown carelessly it could go out of control and cause serious human injury or property damage. Before flying your airplane, ensure the air field is spacious enough. Always fly it outdoors in safe areas and seek professional advice if you are unexperienced.

**ACHTUNG!** Dieses ferngesteuerte Modell ist KEIN Spielzeug! Es ist für fortgeschrittene Modellflugpiloten bestimmt, die ausreichende Erfahrung im Umgang mit derartigen Modellen besitzen. Bei unsachgemäßer Verwendung kann hoher Personen- und/oder Sachschaden entstehen. Fragen Sie in einem Modellbauverein in Ihrer Nähe um professionelle Unterstützung, wenn Sie Hilfe im Bau und Betrieb benötigen. Der Zusammenbau dieses Modells ist durch die vielen Abbildungen selbsterklärend und ist für fortgeschrittene, erfahrene Modellbauer bestimmt.

## REQUIRED FOR OPERATION (Purchase separately) BENÖTIGTE KOMPONENTEN FÜR DEN ABFLUG (Nicht enthalten)



Minimum 5 channel radio for airplane with 4-5 servos  
 .Motor control x1 .Aileron x2  
 .Elevator x1 .Rudder x1



10.5x6 for .40 - 2 cycle engine  
 11x6 for .46 - 2 cycle engine  
 12x6 for .60 - 4 cycle engine  
 12x7 for .70 - 4 cycle engine  
 13x6 for Electric Motor

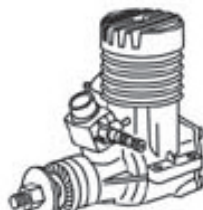

.46 - .50 - 2 cycle

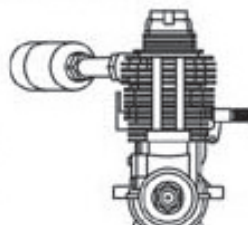

.60 - .70 - 4 cycle



Silicone tube



Li-Po Battery, 4000mAh, 80A



Retract servo x1

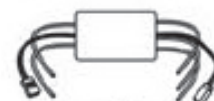

Brushless Motor Control



650 Watts Brushless Motor or equivalent.



Extension for aileron servo, retract servo.

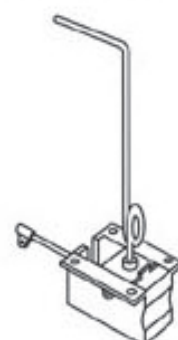

Retract landing gear VQAR04



Linkage Stopper x2 (for retract servo)

## GLUE (Purchase separately)

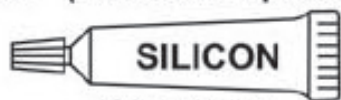

Silicon sealer



Cyanoacrylate Glue

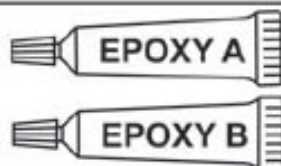

Epoxy Glue ( 5 minute type)

Epoxy Glue (30 minute type)

## TOLLS REQUIRED (Purchase separately)

Hobby knife 

Phillip screw driver 

Hex Wrench 

Needle nose Pliers 

Scissors 

Awl 

Sander 

Wire Cutters 

Masking tape - Straight Edged Ruler - Pen or pencil - Rubbing alcohol - Drill and Assorted Drill Bits

If exposed to direct sunlight and/or heat, wrinkles can appear. Storing the model in a cool place will let the wrinkles disappear. Otherwise, remove wrinkles in covering film with a hair dryer, starting with low temperature. You can fix the corners by using a hot iron.

Bei Sonneneinstrahlung und/oder Wärme kann die Folie erschlaffen bzw. Falten entstehen. Verwenden Sie ein Warmluftgebläse (Haartrockner) um evtl. Falten aus der Folie zu bekommen. Die Kanten können Sie mit einem Bügeleisen behandeln. Nicht zuviel Hitze anwenden!

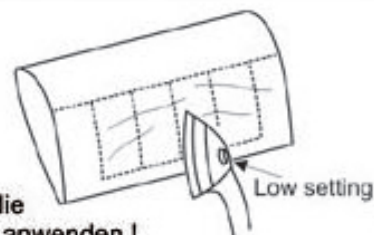



Symbols used throughout this instruction manual, comprise:

 Drill holes using the stated size of drill (in this case 1.5 mm Ø)

 Take particular care here

 Hatched-in areas: remove covering film carefully

 Check during assembly that these parts move freely, without binding

 Use epoxy glue

 Apply cyano glue

 Assemble left and right sides the same way.

 Not included. These parts must be purchased separately

 Löcher bohren mit dem angegebenen Bohrer (hier 1,5 mm)

 Hier besonders aufpassen

 Schraffierte Stellen, Bespannfolie vorsichtig entfernen

 Während des Zusammenbaus immer prüfen, ob sich die Teile auch reibungslos bewegen lassen

 Epoxy-Klebstoff verwenden

 Sekundenkleber auftragen

 Linke und rechte Seite wird gleichermaßen zusammgebaut

 Nicht enthalten. Teile müssen separat gekauft werden.

Read through the manual before you begin, so you will have an overall idea of what to do.

## CONVERSION TABLE

1.0mm = 3/64"	3.0mm = 1/8"	10mm = 13/32"	25mm = 1"
1.5mm = 1/16"	4.0mm = 5/32"	12mm = 15/32"	30mm = 1-3/16"
2.0mm = 5/64"	5.0mm = 13/64"	15mm = 19/32"	45mm = 1-51/64"
2.5mm = 3/32"	6.0mm = 15/64"	20mm = 51/64"	

# 1- Wing

Top view / Ansicht von Oben

Use epoxy glue to bury the opening  
Nehmen Sie Epoxykleber, um die Tragflächen fest miteinander zu Verbinden und streifen Sie den herausquellenden Kleber nach dem Verbinden mit einem fusselfreien Tuch SOFORT ab!



Secure one end of the aileron extension cord with adhesive tape

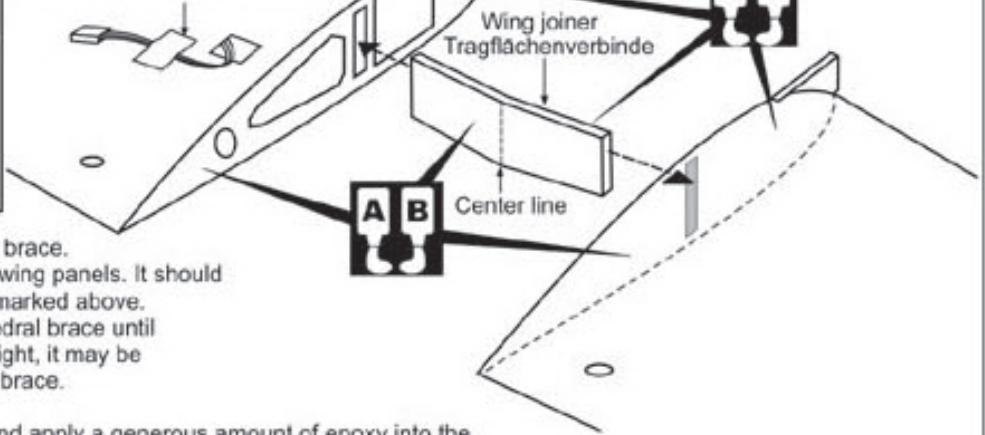

- 1- Using a pencil, mark the center of the brace.
- 2- Trial fit the wing joiner into one of the wing panels. It should insert smoothly up to the center line marked above.
- 3- Slide the other wing half onto the dihedral brace until the wing panel meet. If the fit is over tight, it may be necessary to lightly sand the dihedral brace.
- 4- Check for the correct dihedral angle.
- 5- Mix approximately 30 minute epoxy and apply a generous amount of epoxy into the wing joiner cavity of one wing half.
- 6- Coat one half of the dihedral brace with epoxy up to the center line. Install the epoxy-coated side of the dihedral brace into the wing joiner cavity up to the center line, marking sure that the "V" of the dihedral brace is positioned correctly
- 7- Do the same way with the other wing half.
- 8- Carefully slide the wing halves together, ensuring that they are accurately aligned. Firmly press the two halves together, allowing the excess epoxy to run out. Clear off the excess epoxy.

**WARNING:** Please do not clean off the excess epoxy on the wing with strong solvent or pure alcohol, only use kerosene to keep the colour of your model not fade.

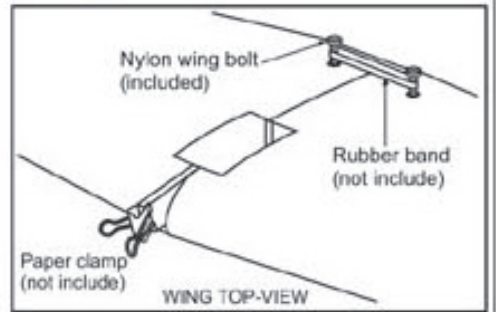

# 2- Retract landing gear

Trial fit the push rod into the wing. Join the pushrod to the retract gear arm and trial fit the retract into the wing.

Pull and push the retract push rod by hand to be sure to adjust the stroke so that the landing gear locks in both up and down position.

After checking that the retract works smoothly with the servos, fix the retract on the wing with 3x15mm screws.

Bottom view / Ansicht von unten

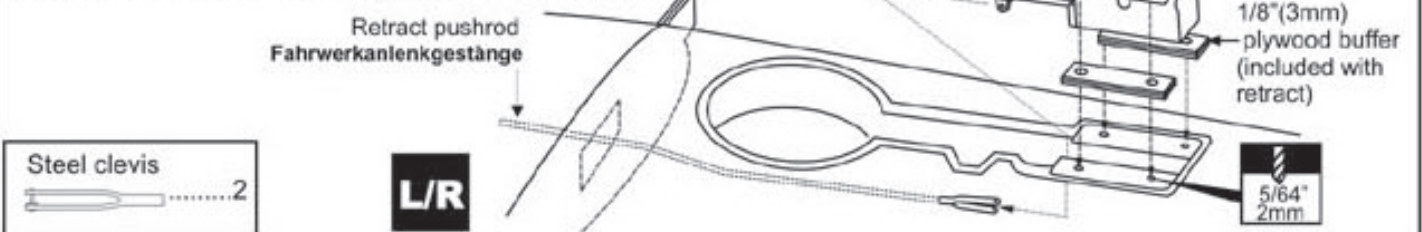

L/R

# 3- Aileron servo

Aileron extension cord  
Servoverlängerungskabel

Bottom view  
Ansicht von unten

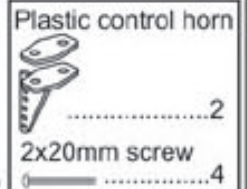

Top view / Ansicht von Oben

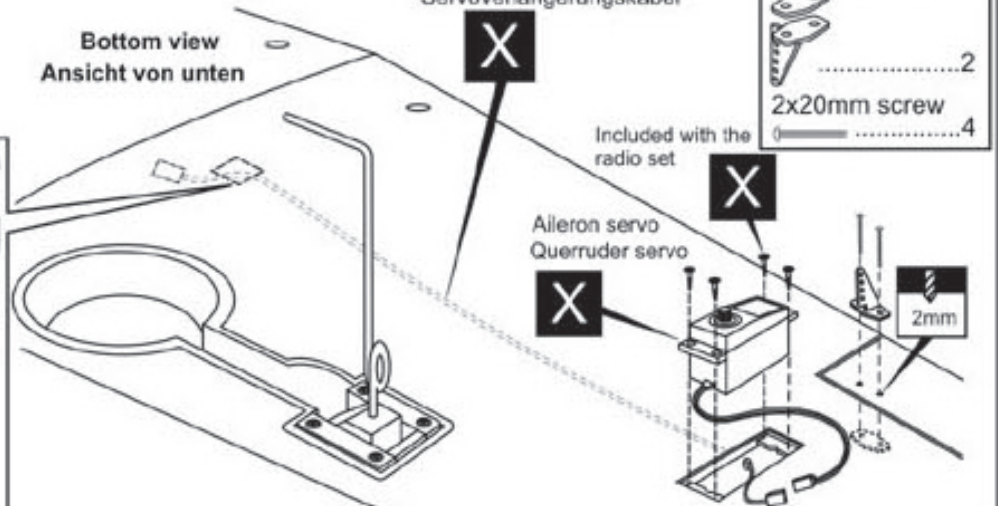
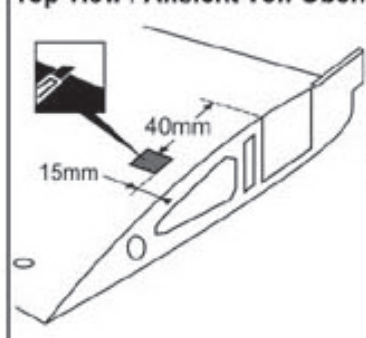

#### 4- Retract servo mount

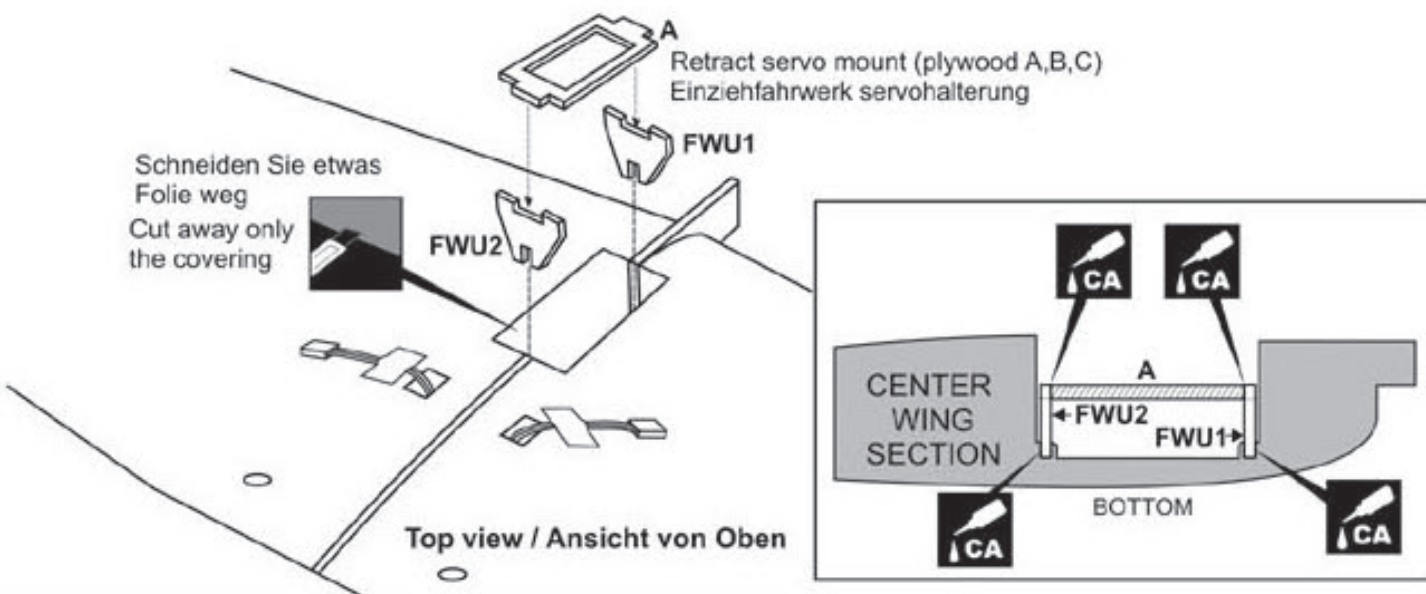

#### 5- Retract servo

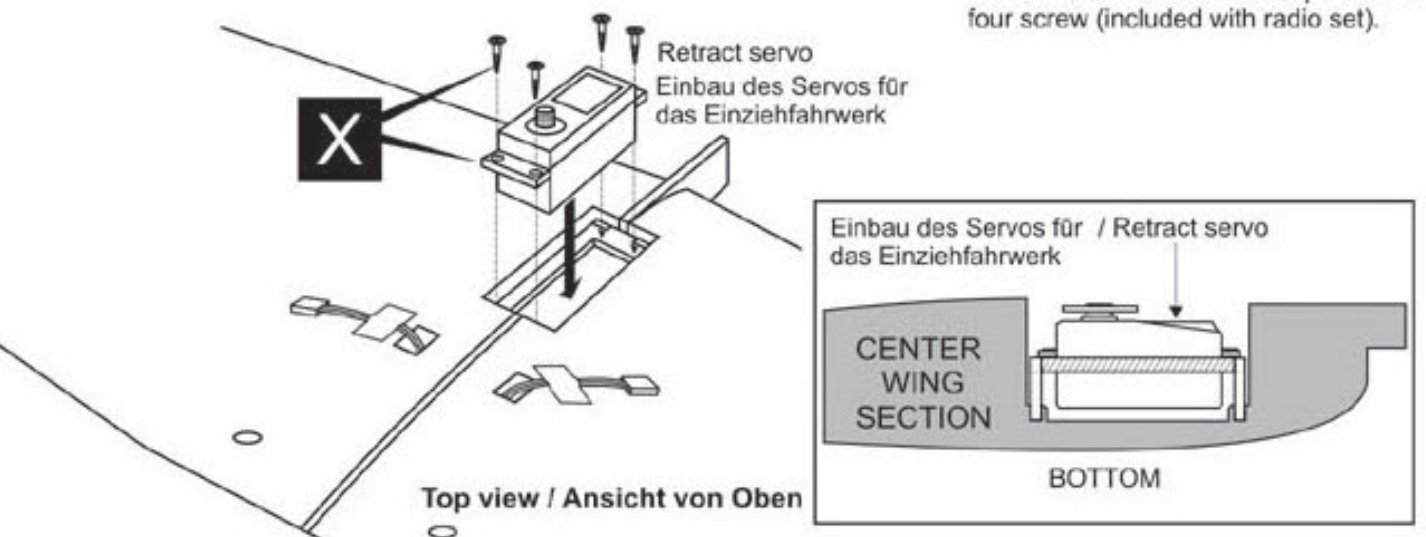

#### 6- Linkage

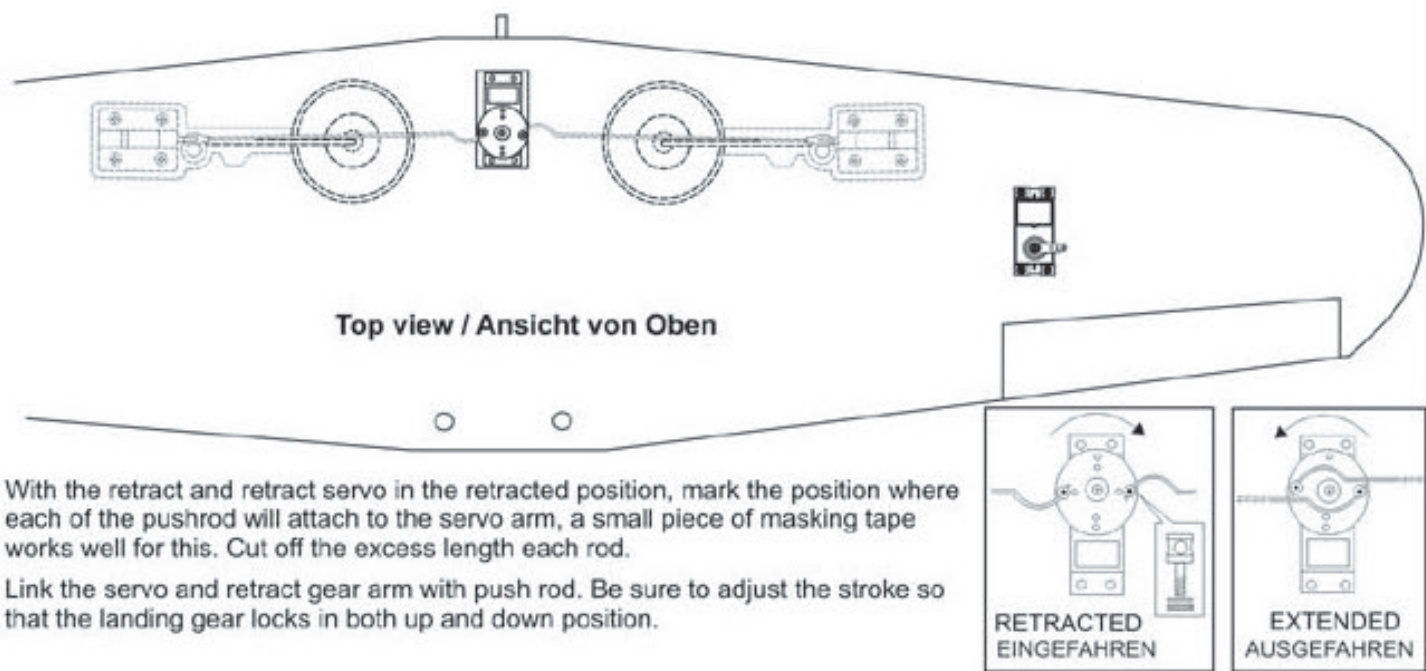

## 7- Fixed gear

- 3x12mm screw  .....8
- 3x20mm screw  .....16
- Nylon gear strap  .....4
-  .....4
-  Gear mount x 2
-  Ply gear mount plate x 2
-  Square plastic x 2

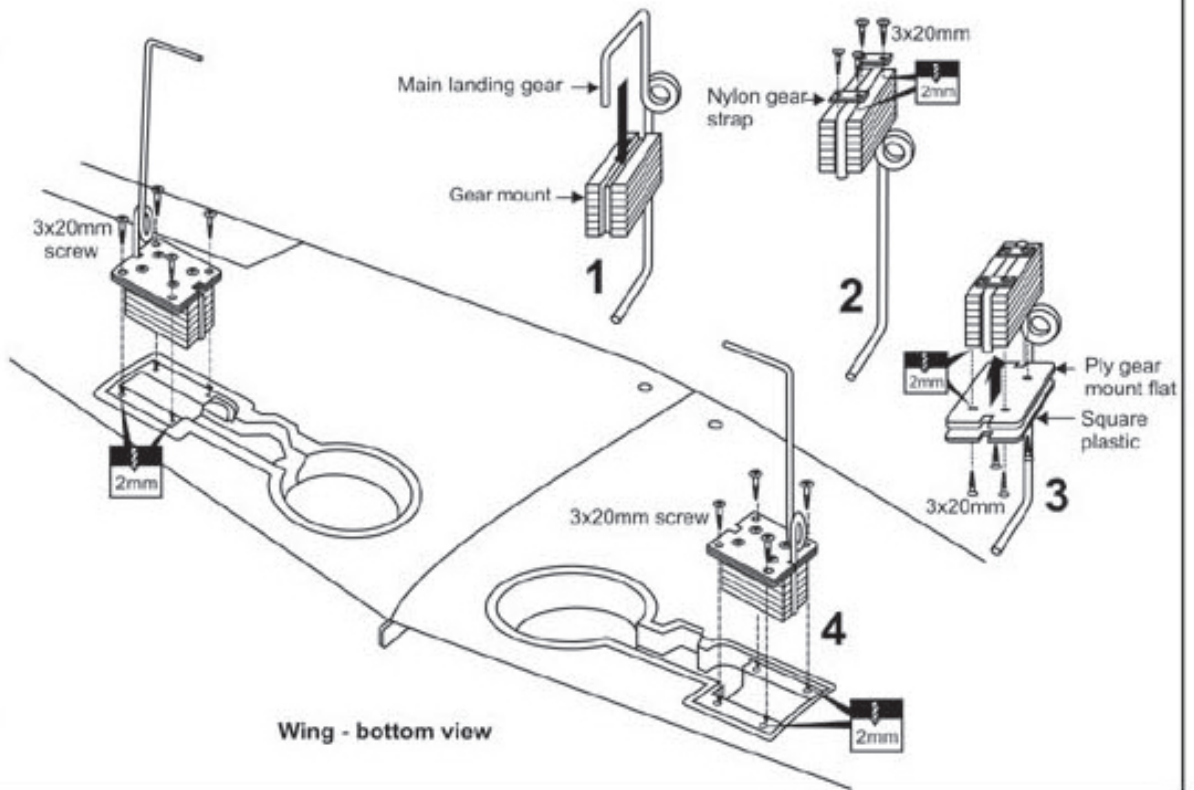

## 8- Fixed gear

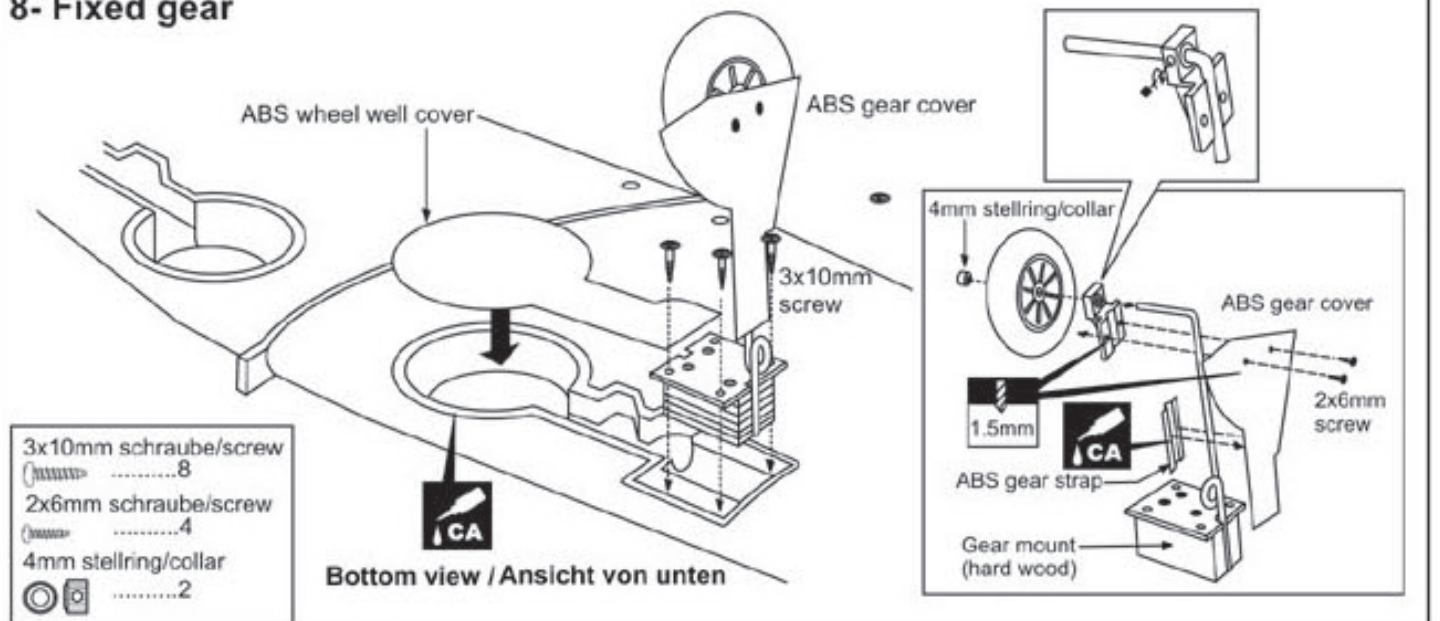

## 9- Electric retract landing gear

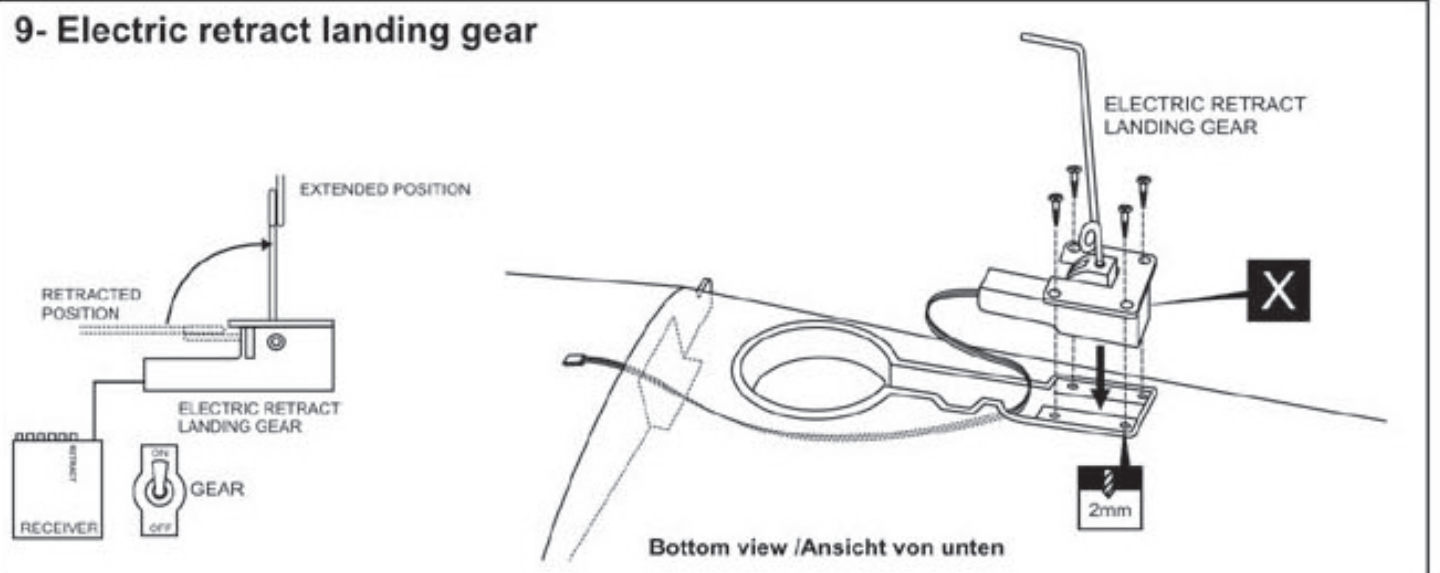

## 10- Wing installing

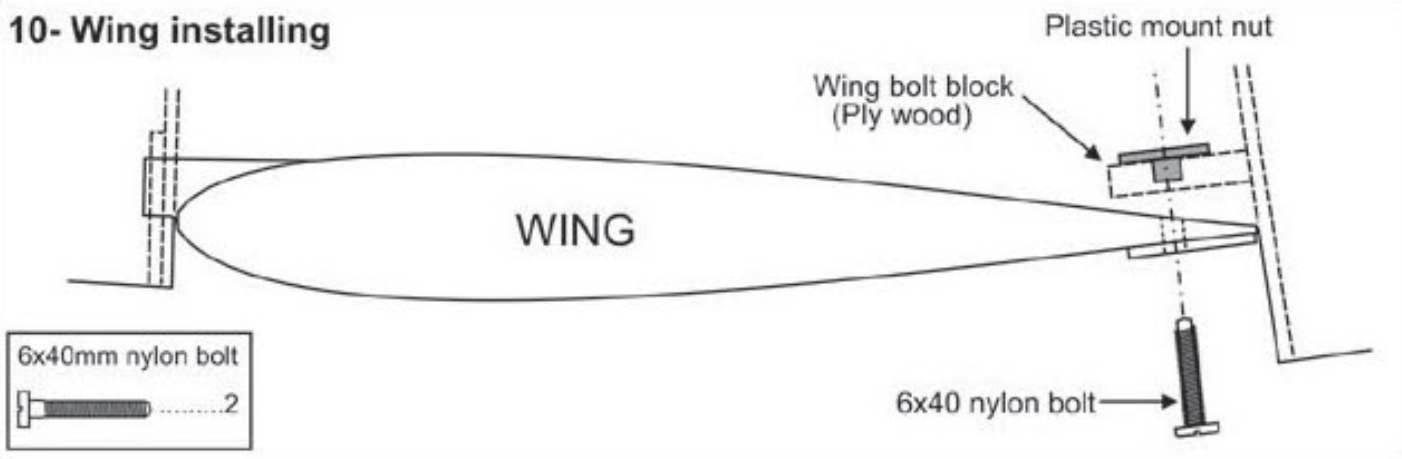

## 11- Air scoop

Using the ABS air scoop as a template, with a pencil, trace around the outside edge of the ABS air-scoop and then remove it. Using a sharp hobby knife, cut away the covering inside the lines. Not to cut into the wood. Apply the ABS air scoop in place and secure with CA glue.

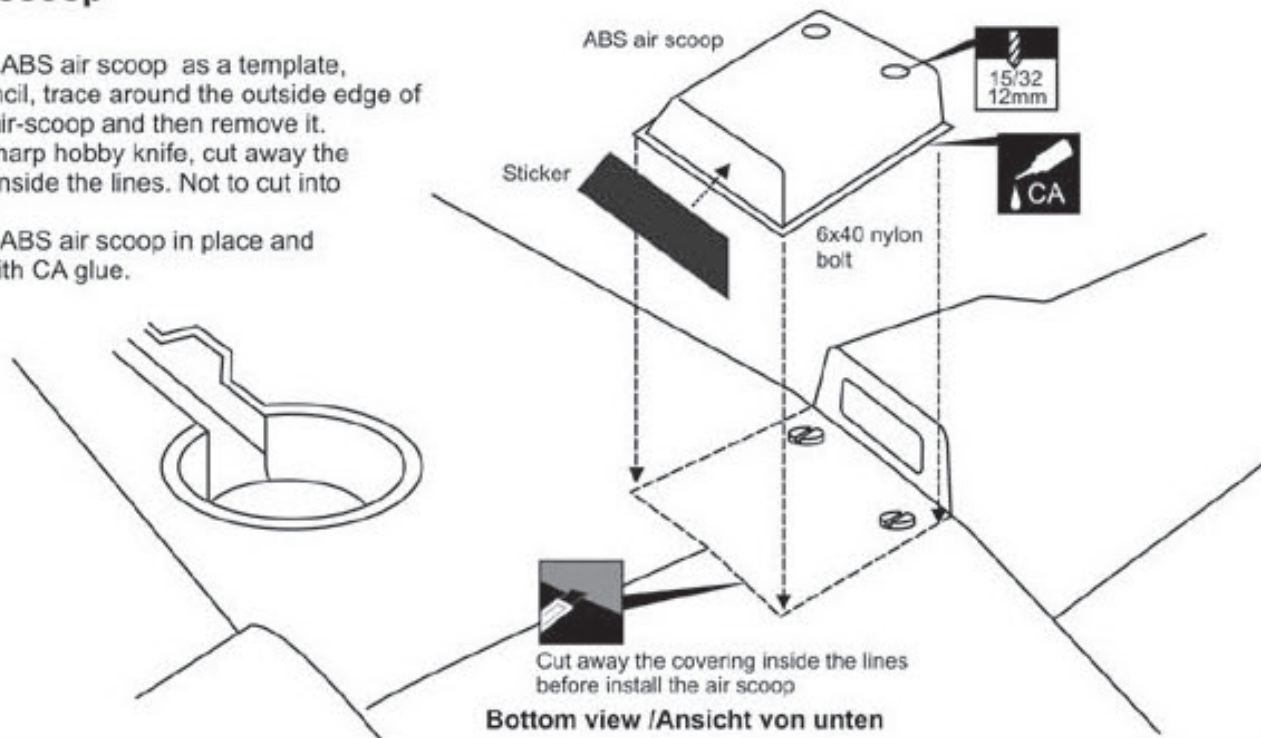

## 12- Horizontal stabilizer

- 1-Trial fit the horizontal stabilizer in place. Check the alignment of the horizontal stabilizer. When you are satisfied with the alignment, use a pencil to trace around the top and bottom of the stabilizer where it meets the fuselage.
- 2-Remove the horizontal stabilizer from the fuselage. Using the sharp hobby knife, carefully cut away the covering inside the lines which were marked above.
- 3-Spread epoxy (30 minute) onto the top and bottom of the horizontal stabilizer along the area where the covering was removed and to the fuselage where the horizontal stabilizer mounts.
- 4-Install the horizontal stabilizer into the fuselage and adjust the alignment as described in step 1. Allow the epoxy to cure before proceeding to next step.

*Securely glue together. If coming off during flight, you lose control of your air plane!*

**Vergewissern Sie sich, sauber geklebt zu haben. Andernfalls können Probleme mit der Flugeigenschaft auftreten!**

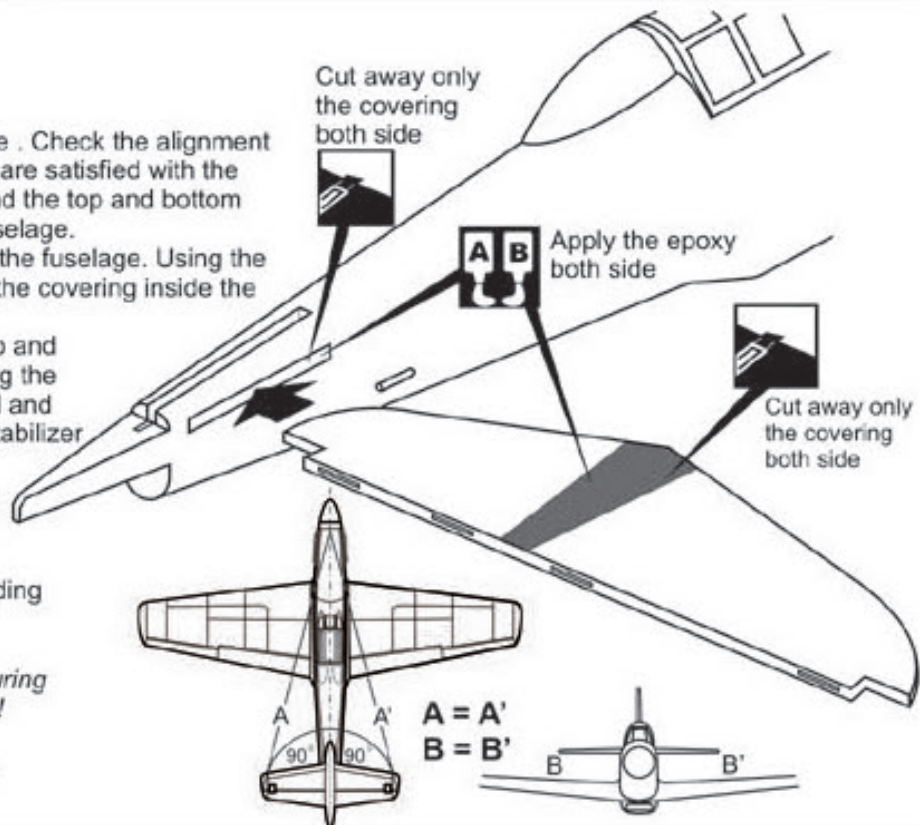

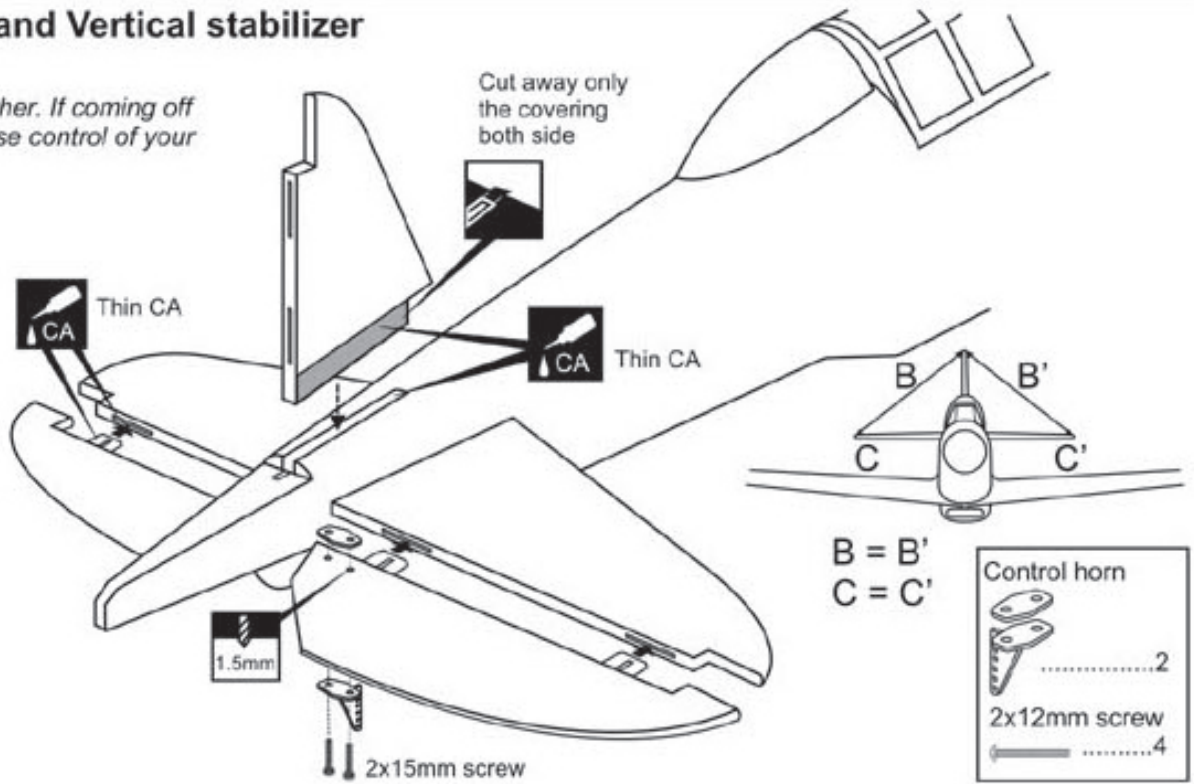

### 13- Elevator and Vertical stabilizer

Securely glue together. If coming off during flight, you lose control of your air plane!



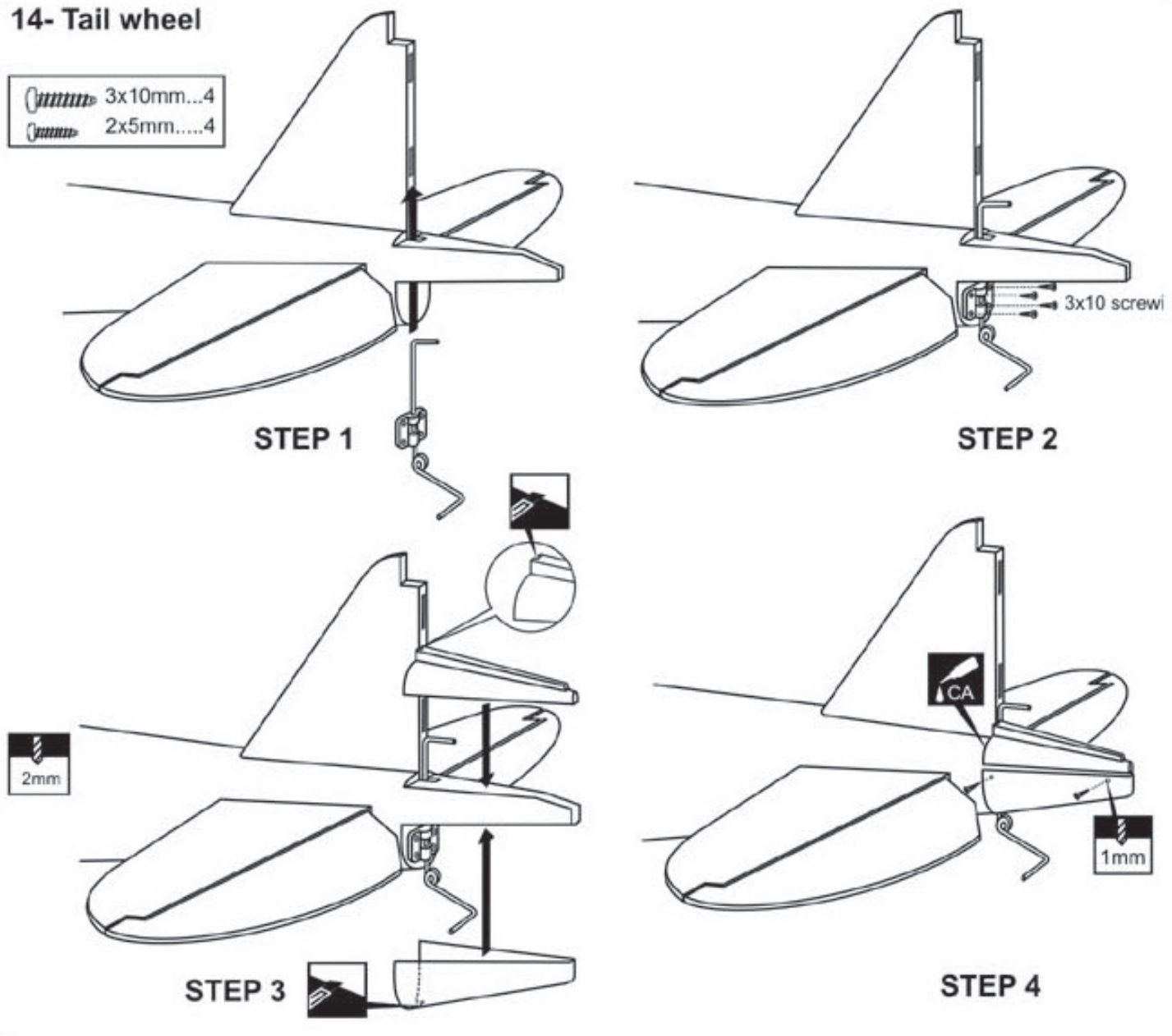

### 14- Tail wheel

-  3x10mm...4
-  2x5mm.....4



## 15- Rudder

- 2mm collar 1
- ⊙ ⊠ ..... 1
- 25mm wheel ..... 1
-  ..... 1
-  ..... 1
- Control horn ..... 1

Replace the rudder on the trailing edge of vertical stabilizer and secure it in place using thin CA glue

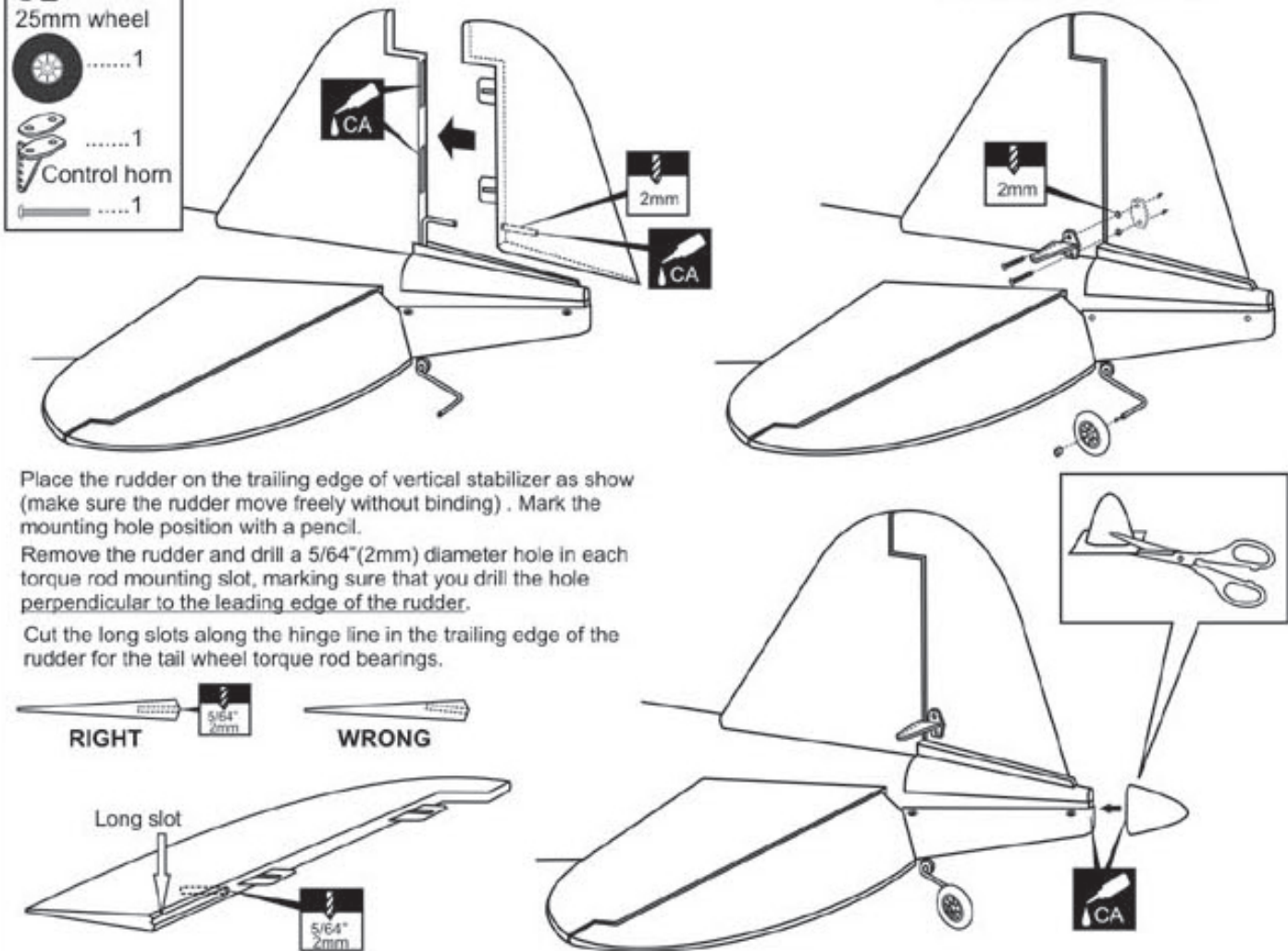

## 16- Motor mounting plate

- Using a plywood motor mounting plate as a template, mark the fire wall where the four holes are to be drilled (1).

- Remove the plywood motor mounting plate and drill a 13/64"(5mm) hole through the fire-wall at each of the four marks marked (2).
- Using a aluminum motor mounting plate as a template, mark the plywood motor mounting plate where the four holes are to be drilled (3).
- Remove the aluminum motor mounting plate and drill a 1/8"(3mm) hole through the plywood at each of the four marks marked (4).

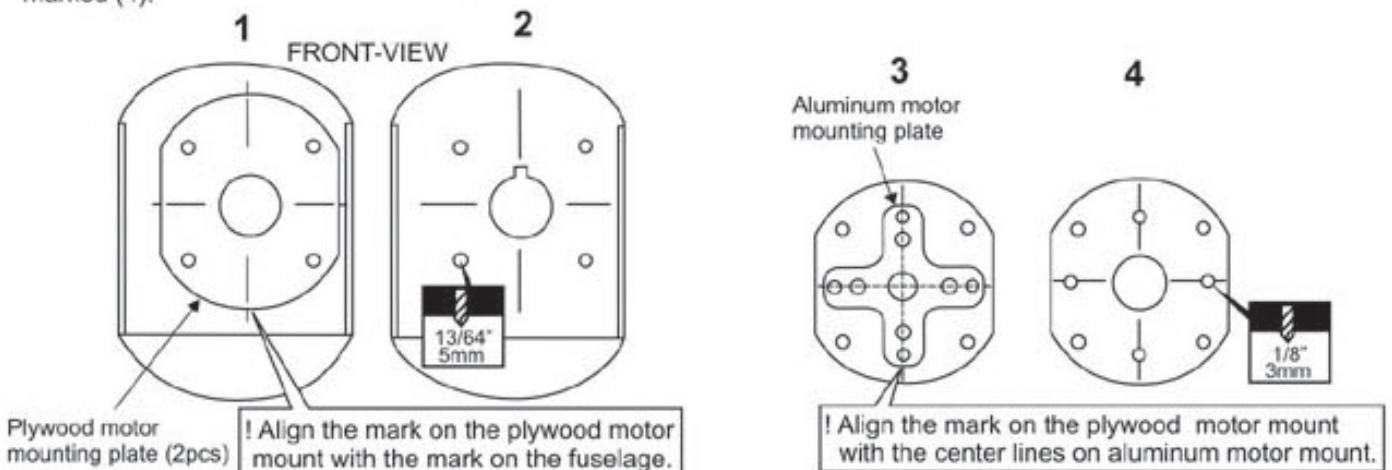



## 17- Brushless motor installation

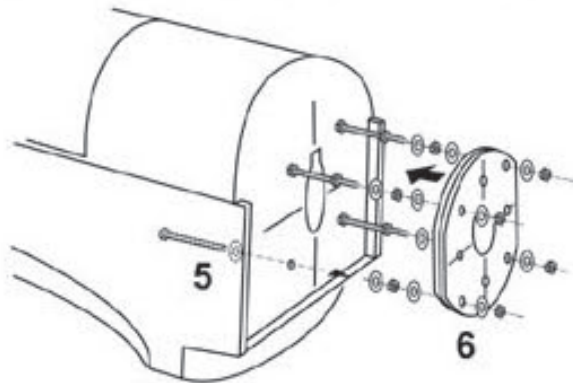

- Push the four 5x70mm bolts through the fire-wall as shown (5).
- Reposition the plywood motor mounting plate (2pcs) and secure it in place with eight 5mm nuts and washers (6).  
Note: B=B'(Side-view) and A=A'(Top-view)
- Attach the aluminum motor mounting plate on to the motor and secure it in place with four screws ( included with motor set) (7).
- Attach the motor on to the plywood motor mounting plate and secure it in place with four 3x15mm (1/8x19/32") screws(8).

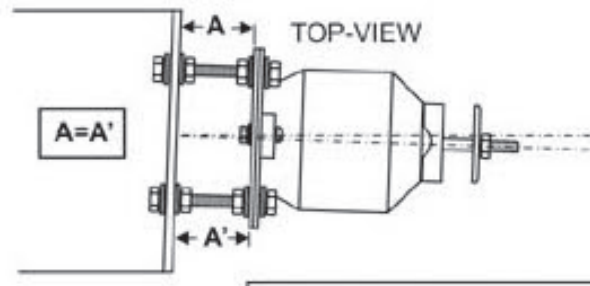
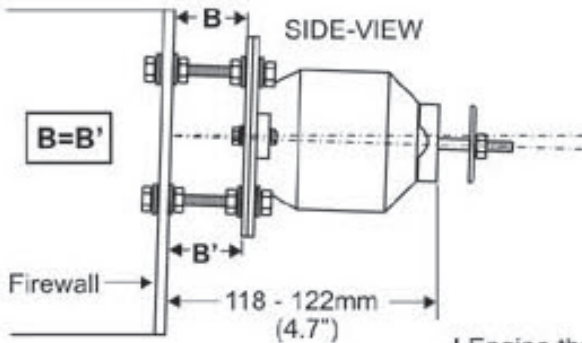
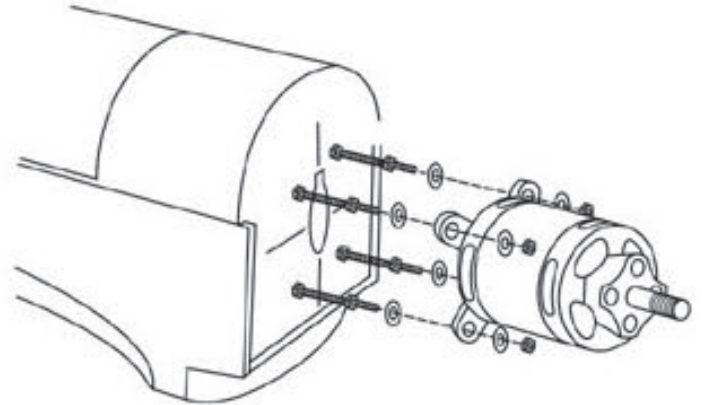
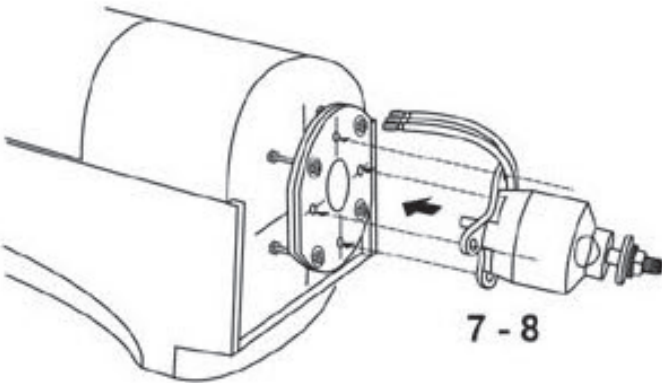

! Engine thrust on balk head is already adjust at factory

5x70mm.....4	5mm washer...16
5mm nut.....12	3mm screw/nut...4

## 18- Engine mount

Plastic engine mounts

Full out the magnetic top hatch out of the fuselage before install the engine mount.

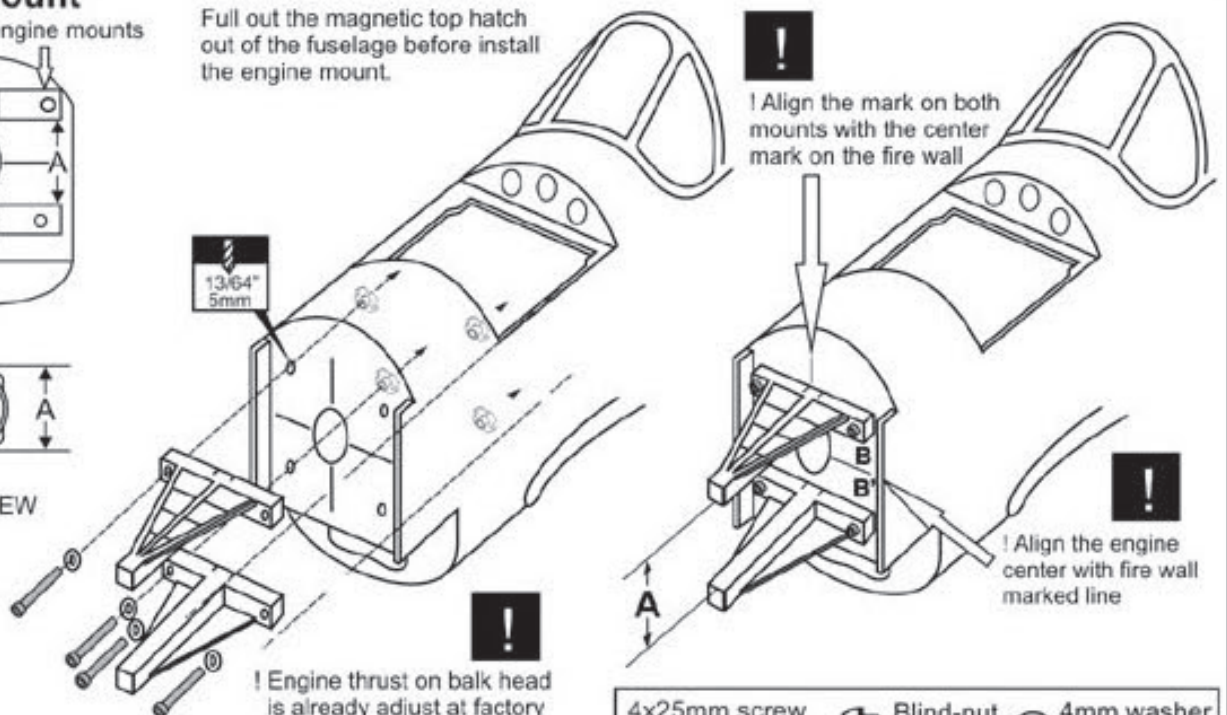
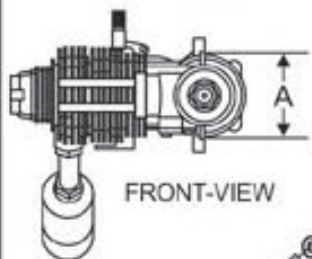
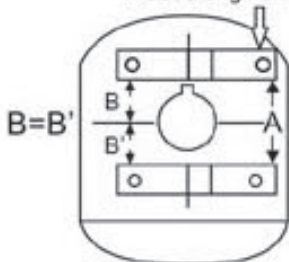

4x25mm screw .....4	Blind-nut .....4	4mm washer .....4
---------------------	------------------	-------------------

## 19- Engine (4 stroke)

Top view / Ansicht von Oben

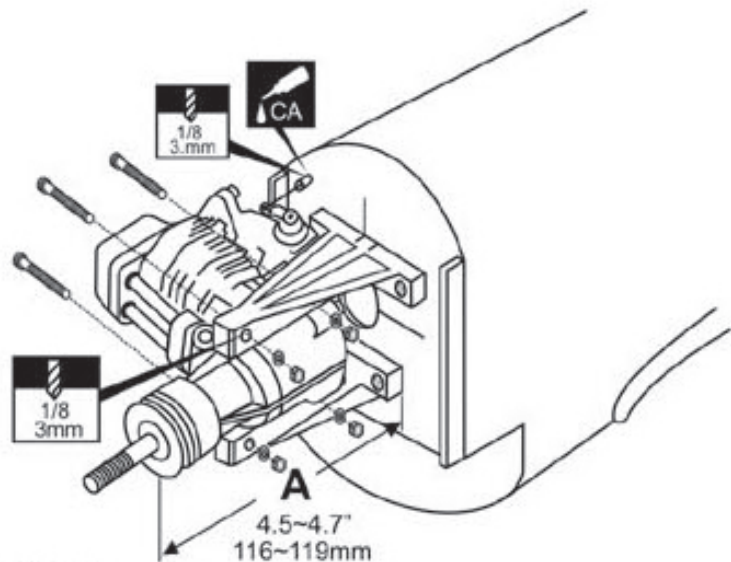
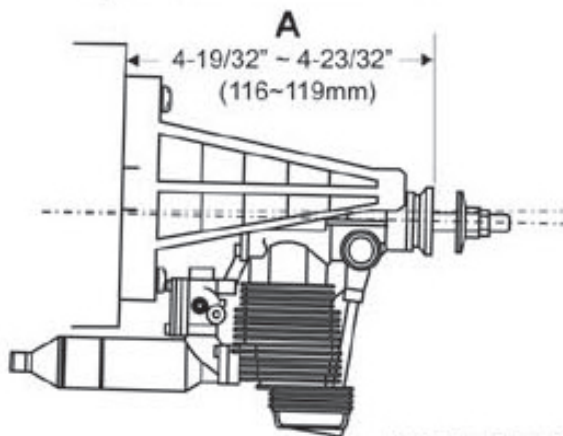

! Engine thrust on balk head is already adjust at factory

## 20- Engine (two stroke)

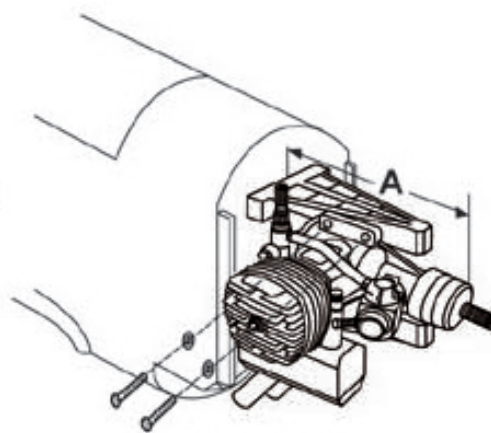
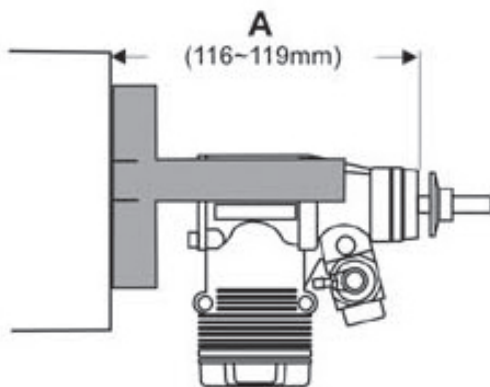

With hang silencer

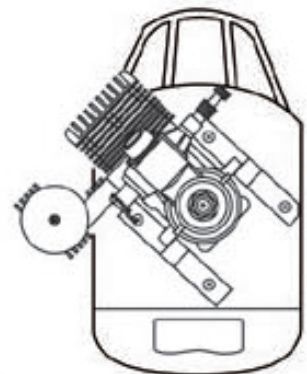

With side silencer

Determine the angle for the engine mounts so the muffler will not contact the fuselage

3x20mm screw



Nut



.....4

## 21- Fuel tank

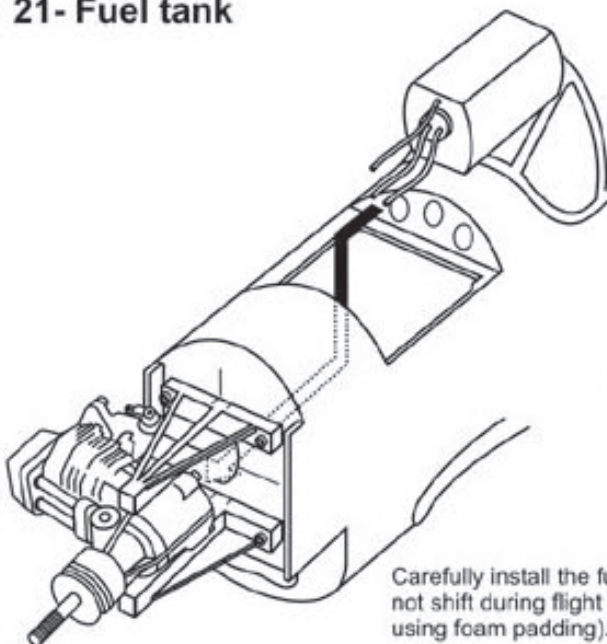

After confirming the direction . Insert this assembly, clunk end first, into the fuel tank and tighten and screw the fuel tank cap on firmly.

Ensure that the fuel tank clunk does not touch the rear of the fuel tank.



Checking for leaks - block the vents and blow into the feed - if in doubt submersing the tank in a blow of water will show up any problems.



Carefully install the fuel tank to ensure that they will not shift during flight (secure the fuel tank in place using foam padding).

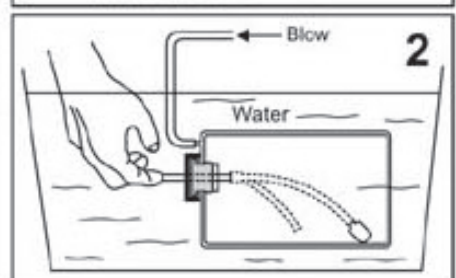
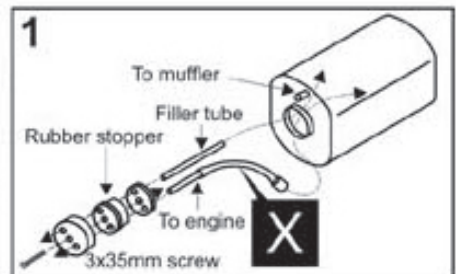

## 22- Cowling

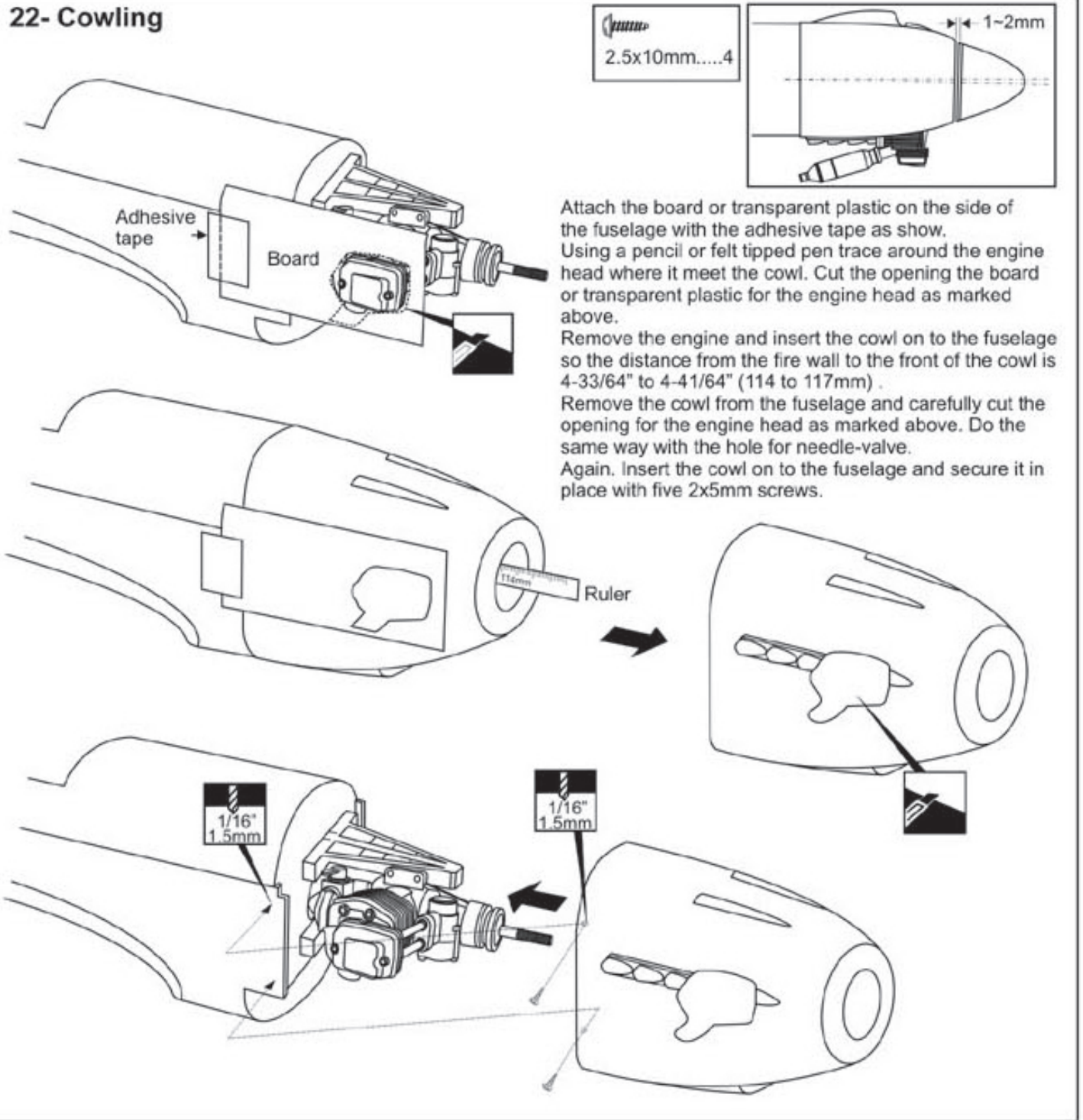

Attach the board or transparent plastic on the side of the fuselage with the adhesive tape as show. Using a pencil or felt tipped pen trace around the engine head where it meet the cowl. Cut the opening the board or transparent plastic for the engine head as marked above.

Remove the engine and insert the cowl on to the fuselage so the distance from the fire wall to the front of the cowl is 4-33/64" to 4-41/64" (114 to 117mm) .

Remove the cowl from the fuselage and carefully cut the opening for the engine head as marked above. Do the same way with the hole for needle-valve.

Again. Insert the cowl on to the fuselage and secure it in place with five 2x5mm screws.

## 23- Servo

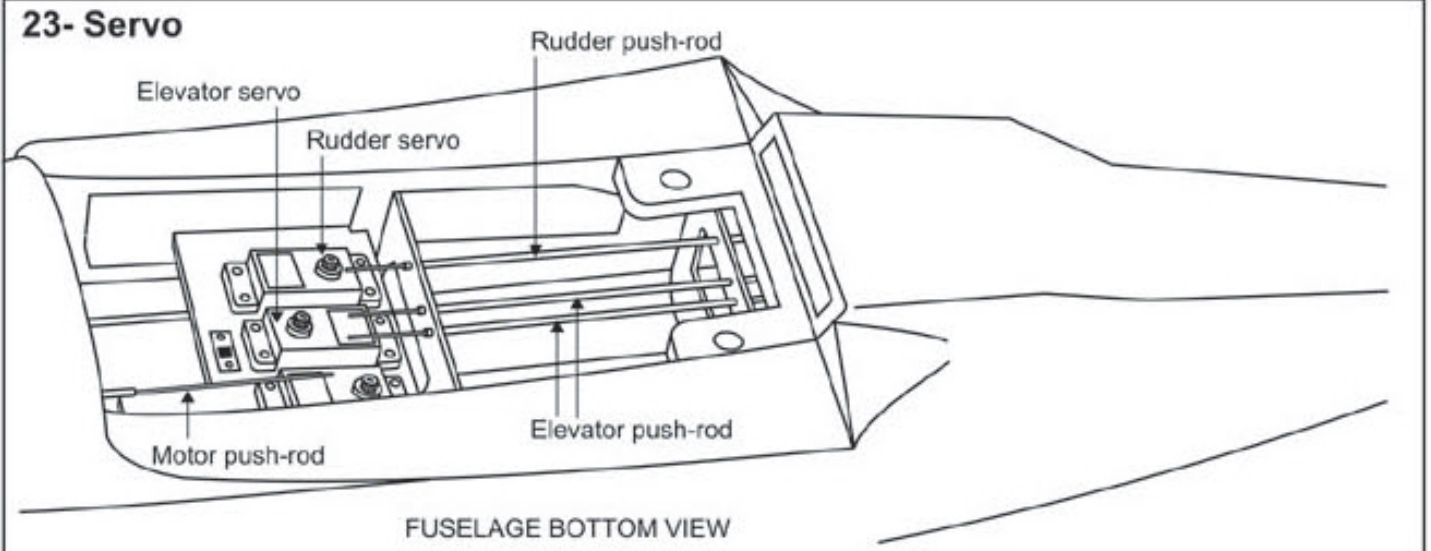

## 24- Linkages

Connector

 ..... 2

 ..... 1

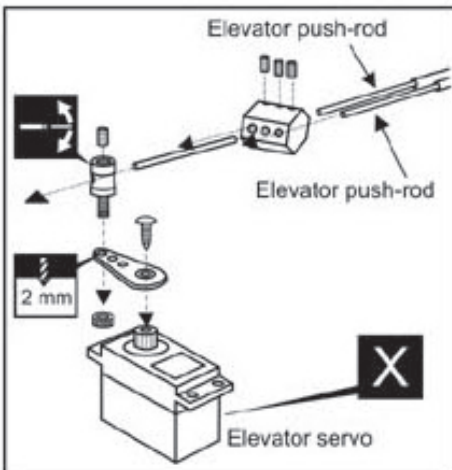
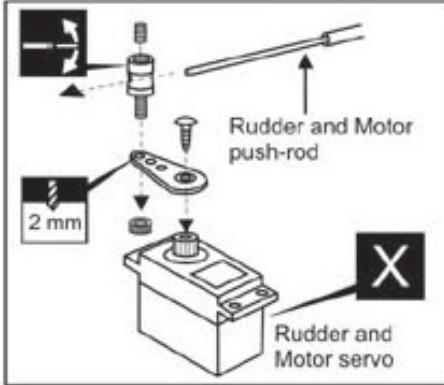

FUSELAGE BOTTOM VIEW

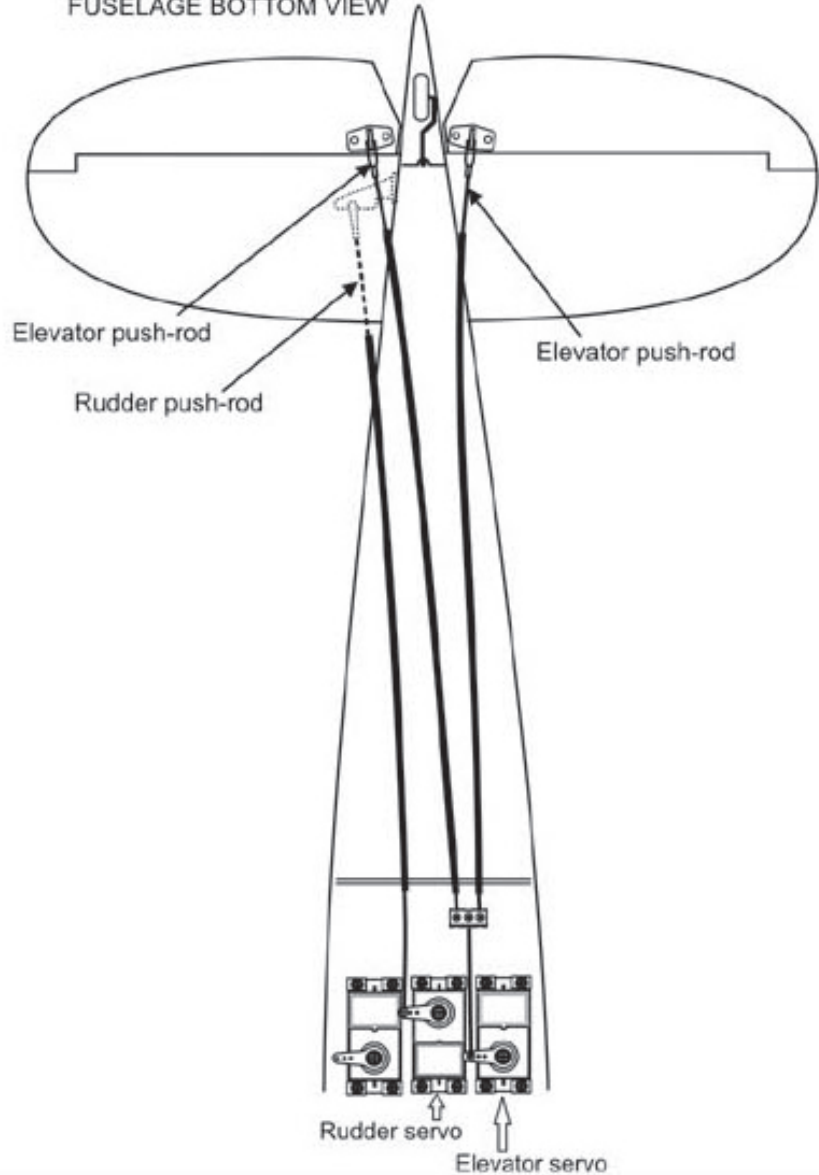

## 25- Balance

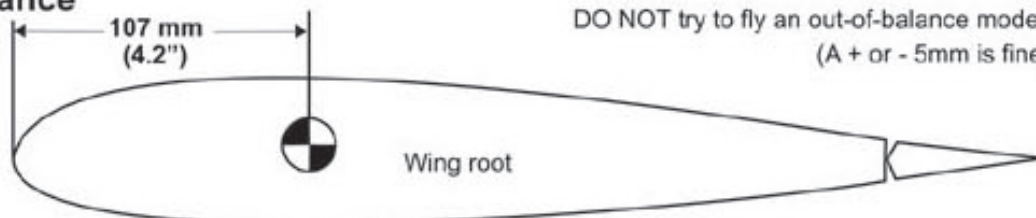

DO NOT try to fly an out-of-balance model !  
(A + or - 5mm is fine)

Note: Adjust the location of the battery pack to achieve this C.G. location.

## 26- Control surface

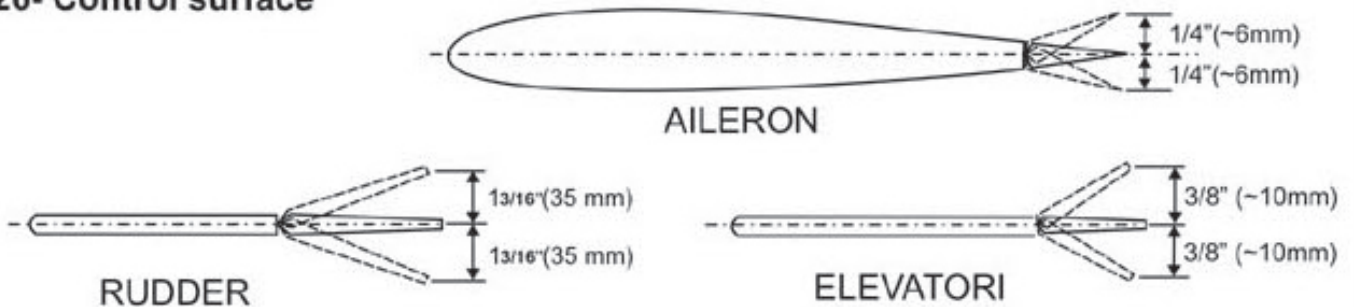

IMPORTANT: Flying your model at these throws will provide you with the greatest chance for successful first flights. If, after you have become accustomed to the way the Mig-3 flies, you would like to change the throws to suit your taste that is fine. However, too much control throw could make the model difficult to control, so remember, "more is not always better".

## 27- Decor

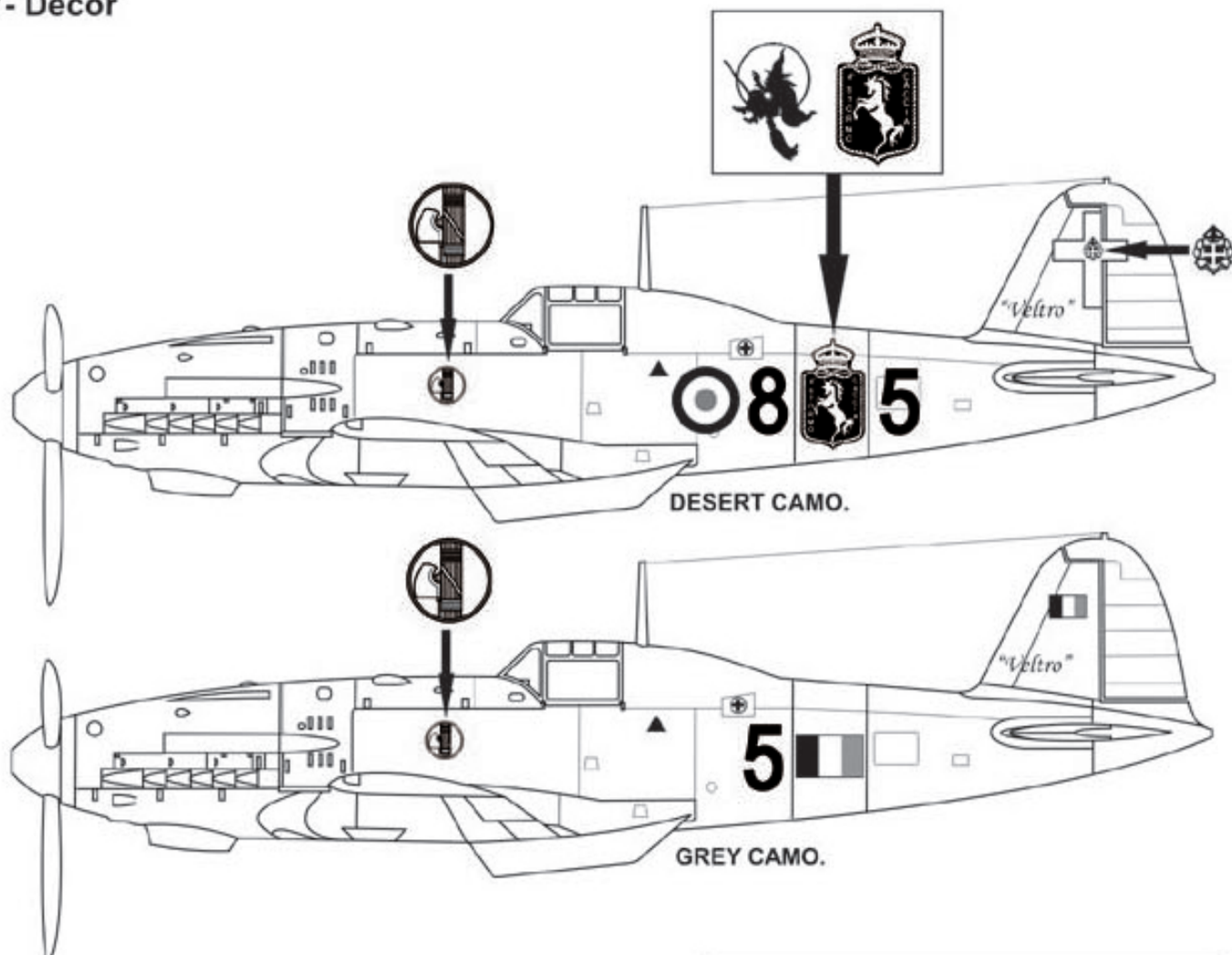

Note: Cut out the stickers and apply them in the proper area. Do not peel the backing paper off all at once.

Peel off one corner of the backing and cut off with scissors. Arrange sticker on model and when satisfied adhere the corner without backing.

Carefully peel back the rest of the backing while at the same time adhering the rest of the sticker.

Try not to make air bubbles, if there are some, carefully puncture sticker (center of bubble) but not model surface with the tip of the knife or sharp pin and squeeze out the air. At curves stretch sticker and apply a little heat so that no creases occur. Cut off the excess that is produced.

### **IMPORTANT:**

Please do not clean your model with pure alcohol, only use liquid soap with water or use glass cleaner to clean on surface of your model to keep the colour not fade.

### **BEFORE FLYING CHECK EVERYTHING**

Before each flight, inspect the airplane for any loose parts. Check the hinges, make sure the pushrods are still firmly attached, and check the engine mounting bolts. In general, check everything on the plane that might possibly come loose.

### **SAFETY NOTES AND WARNINGS RELATING TO MODEL AIRCRAFT POWERED BY GLOWPLUG ENGINE**

Adjust the engine always from behind, but never from in front or the sides as rotating propeller may badly injure you! Do not allow watching people to get too close to a rotating propeller.

Ensure the spinner and propeller are securely attached. Immediately disuse defective propeller as well as deformed spinners.

Be sure to keep an adequate supply of fuel in the tank. Don't continue to fly the model until the tank is drained dry. Never fly directly over people or fly directly towards people.

This model is highly pre-fabricated and can be built in a very short time. However, the work which you have to carry out is important and must be done carefully. The model will only be strong and fly well if you complete your tasks competently - so please work slowly and accurately.

